

Odyssey

Manufactured by **Dakota Digital**

HLY-1111

HEAD TEMPERATURE GAUGE

Introduction:

The Odyssey gauge series from Dakota Digital, Inc. incorporates the reliability and quality of our standard gauges, along with several unique features and easy mounting. These features include:

- Weather-proof construction.
- A warning feature that flashes the gauge readout when outside operating limits.
- A connection for an external warning indicator that is activated when the gauge flashes.
- User adjustable warning points.
- Microprocessor stabilized readings.
- Quick-Start feature to provide accurate readings quickly after being powered up.
- Night dimming with lens label lighting.
- High Visibility VFD display for sunlight readability.

The head temperature gauge will read the temperature of the engine block heads using a sensor mounted onto one of the head bolts. The engine head temperature gives an indication of whether the engine is overheating.

The head temp gauge uses a thermocouple sensor to measure the temperature. A thermocouple actually measures the temperature difference between the ends of its wire. The thermocouple consists of the bolt on sensor and the cable which connects it to the sensor amplifier. Because the thermocouple only measures the temperature difference, the amplifier circuit has a temperature sensor so that the temperature at the amplifier end of the thermocouple wire is known. The gauge then adds the two temperatures together to display the actual head temperature.

The head temperature gauge will operate and read correctly between the temperature range of 0 - 700° F. The gauge has a user adjustable high warning level. This can be set to indicate when the engine head temp is exceeding recommended limits.

Operation:

The gauge needs only the red and black wires connected to light up. The 4-pin connector attaches to the sensor amplifier. The 2-pin sensor cable connects to the amplifier. **The sensor/amplifier must be Dakota Digital part SEN-1111.** Sending units from other manufacturers will cause incorrect readings. SEN-11-1 has a 6' cable. If the sensor wire is not connected, the display will show "EE". When the blue wire has 12 volts, it will dim the display for night viewing. The yellow wire will provide a ground output when the gauge reading is outside the high warning limit.

Setting the warning limit:

The high warning limit can be set to different values. Once it has been set, it is stored internally so that the gauge will retain the values even when the gauge does not have any power. This value can be set and reset as many times as desired. The procedure for setting the warning limit is as follows:

1. Make sure the key is off so the gauge is not powered.
2. Press and hold the 'SET' button. This is located behind the hole located on the back side of the gauge as shown in figure 1.
3. Turn the key on while the 'SET' button is being held.
4. Release the button. The gauge should show 'HI' and then switch to a reading between 150 and 785.
5. Turn the warning adjustment pot until the desired high temperature limit is showing. The adjustment will then 3/4 rotation from stop to stop. Do not force it past either stop.
6. Press and release the 'SET' button. The gauge should show '--'. The new warning limit is now stored.
7. Turn the key off. The gauge will now operate normally when powered up again.

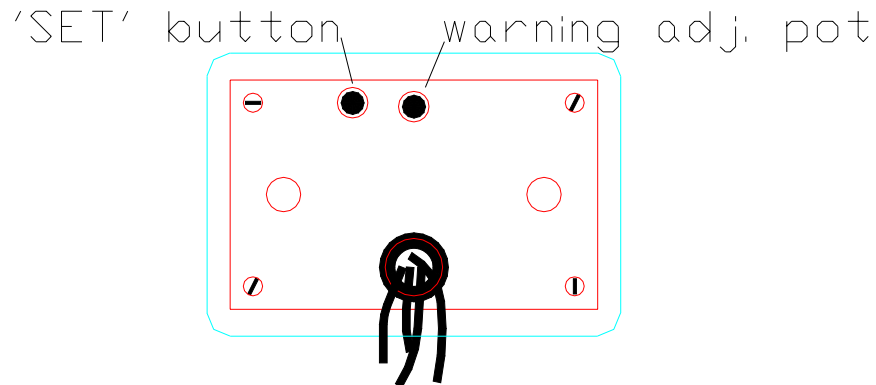

Using external warning indicators:

The yellow wire provides a ground trigger whenever the gauge is outside its set limits. Low current indicators (less than 1/4 A) can be activated directly by connecting their power wire to 12 volts and connecting their ground wire to the yellow output wire. Many gauges can share the same indicator by connecting their yellow warning wires together. In this way, when any one or more gauges are outside their limits the warning indicator will be activated.

For higher current buzzers or lights, a relay will need to be used to switch the indicator on. Dakota Digital's RLY-1 30A relay may be used for this. One of the coil wires should be connected to 12 volts and the other coil wire connected to the yellow warning wire. When the gauge is outside its limits, the relay will turn on. The relay contact wires can be used to switch the higher current.

WARNING!
CONNECTING A HIGH CURRENT INDICATOR
DIRECTLY TO THE WARNING OUTPUT WILL
DAMAGE THE UNIT.

Wiring:

- BLACK - connect to a good ground point in the vehicle.
- RED - connect to an accessory terminal from your fuse block.
- 4-wire connector - connect to mating connector from sensor amplifier.
- 2-wire connector - plug into the end of the sensor amplifier.
- BLUE - connect to a switch for night dimming.
- YELLOW - (optional) connect to warning indicator.

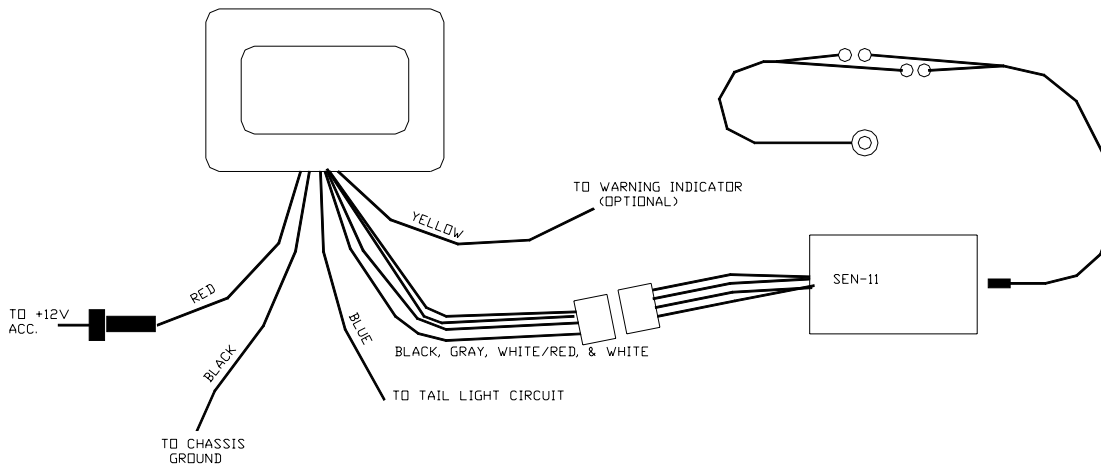

Mounting:

The gauge requires a rectangular cut out that is about 2 9/16" x 1 11/16". It should be inserted into the opening from the front and the U-clamp will be installed from the back. Tighten the two nuts on the U-clamp so that the gauge is secure. Figure 2 shows the required cut out for the gauge. Figure 3 shows how the gauge mounts.

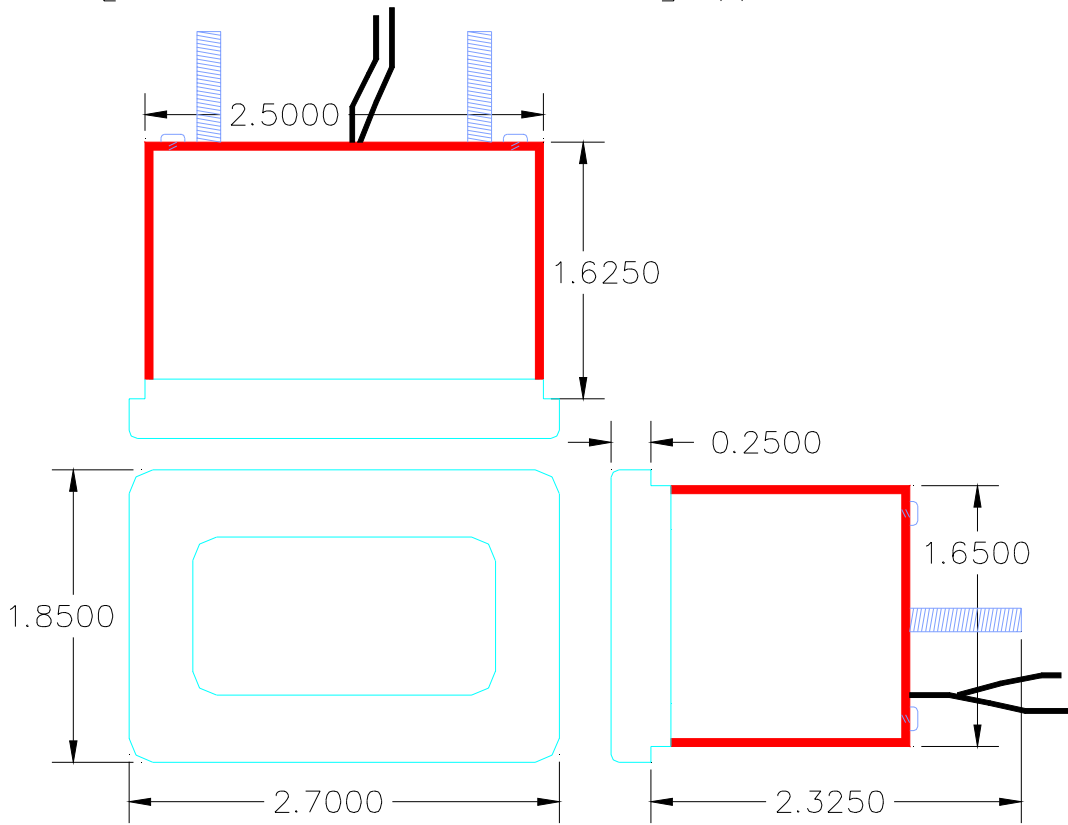
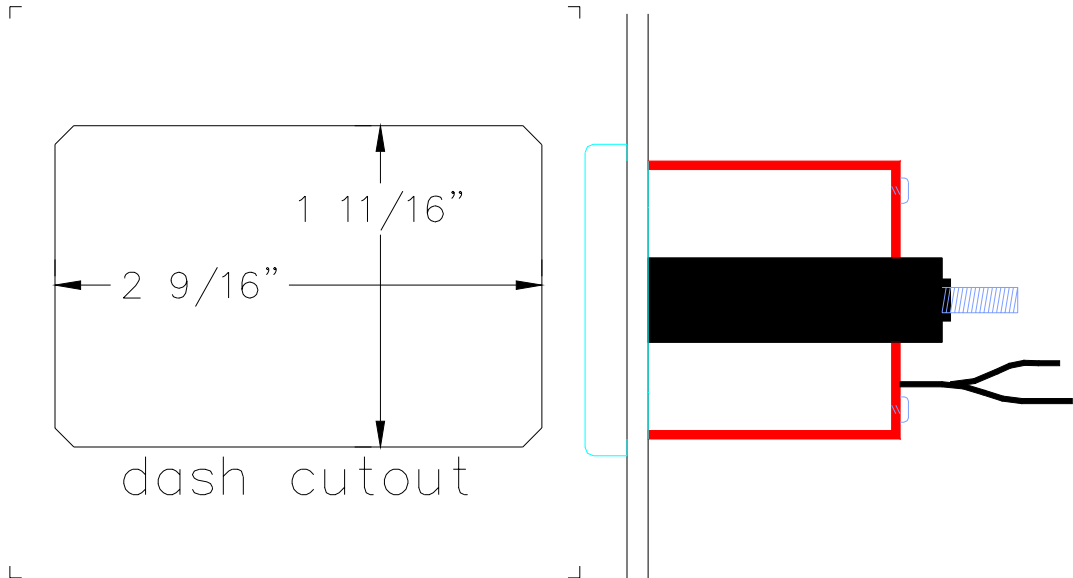

Troubleshooting guide.

Problem	Possible cause	Solution
Gauge will not light up	Red wire does not have power. Black wire is not getting a good ground. Fuse is blown.	Connect to a location that has power. Connect ground to a different location. Replace in line fuse. (2 amp only.)
Gauge lights up, but displays "EE".	Gauge is damaged. Sensor is not connected to amplifier. Wire between amplifier and sensor is broken. Sensor amplifier is not connected to gauge.	Return gauge for repair. (see instructions) Connect gray wire from gauge to sensor terminal. Inspect and test wire. Plug sensor amplifier connector into mating connector from gauge.
Gauge lights up, but displays "--".	Amplifier is damaged. Sensor is damaged. Sensor amplifier is not connected to gauge. Gauge is damaged.	Return gauge for repair. (contact factory) Return amplifier for repair. (contact factory) Return sensor for repair. (contact factory) Plug sensor amplifier connector into mating connector from gauge. Return gauge for repair. (contact factory)
Gauge lights up, but does not read correctly.	Amplifier is damaged. Loose connection on red power wire. Poor ground connection. Incorrect sensor type. Gauge is not calibrated correctly.	Return amplifier for repair. (contact factory) Reconnect red wire. Move ground to different location Make sure sensor is Dakota Digital SEN-1111. Gauge must be recalibrated. (contact factory)
Gauge flashes constantly.	Warning limits are not set properly. Temperature is too high.	Reset warning limits. Check coolant system.
External warning indicator does not work.	Indicator not connected properly. Indicator does not work. Gauge output has been damaged.	Check indicator wiring connections. Repair or replace indicator. Return gauge for repair. (see instructions)
Gauge will not dim.	Blue wire is not connected correctly. Gauge is damaged.	Check wiring connections. Return gauge for repair. (contact factory)
Gauge remains dim at all times.	Blue wire is getting power all of the time. Battery is very low. Gauge is damaged.	Connect blue wire to location that only has power when the headlights are on. Recharge or replace vehicle battery. Return gauge for repair. (contact factory)

Technical specifications

Minimum operating voltage	-	7 volts
Maximum operating voltage	-	18 volts
(operating at or near maximum rating for an extended time can damage unit)		
Maximum temperature reading	-	700° F
Gauge Resolution	-	5° F
Gauge accuracy	-	±10° F
Typical current draw (@ 13.8V)	-	0.13 A
Warning indicator max current	-	0.3 A

SERVICE AND REPAIR

DAKOTA DIGITAL offers complete service and repair of its product line. In addition, technical consultation is available to help you work through any questions or problems you may be having installing one of our units.

Should you ever need to send the unit back for repairs, please package the product in a good quality box along with plenty of packing material. Ship the product by UPS or insured Parcel Post. Be sure to include a complete description of the problem, your full name and address (street address preferred), and a telephone number where you can be reached during the day. An authorization number for products being returned for repair is not needed. Do not send any money. We will bill you for the repair charges. Any returns for warranty work must include a copy of the dated invoice or bill of sale.

ODYSSEY SERIES DIGITAL GAUGE LIMITED WARRANTY

DAKOTA DIGITAL (the Company) warrants to the ORIGINAL PURCHASER of this product that should it, under normal use and condition, be proven defective in material or workmanship within 24 MONTHS FROM THE DATE OF PURCHASE, such defect(s) will be repaired or replaced (at the Company's option) without charge for parts or labor directly related to repairs of the defect(s).

To obtain repair or replacement within the terms of this Warranty, the product is to be delivered with proof of warranty coverage (e.g. dated bill of sale), name, address, phone number, and specification of defects, transportation prepaid, to the factory. This Warranty is valid for the original purchaser only and may not be transferred.

This warranty does not cover nor extend to damage to vehicle electrical system. This Warranty does not apply to any product or part thereof which in the opinion of the Company has been damaged through alteration, improper installation, mishandling, misuse, neglect, or accident.

This Warranty is in lieu of all other express warranties or liabilities. ANY IMPLIED WARRANTIES, INCLUDING ANY IMPLIED WARRANTY OF MERCHANTABILITY, SHALL BE LIMITED TO THE DURATION OF THIS WRITTEN WARRANTY. ANY ACTION FOR BREACH OF ANY WARRANTY HEREUNDER INCLUDING ANY IMPLIED WARRANTY OF MERCHANTABILITY MUST BE BROUGHT WITHIN A PERIOD OF 24 MONTHS FROM DATE OF ORIGINAL PURCHASE. IN NO CASE SHALL THE COMPANY BE LIABLE FOR ANY CONSEQUENTIAL OR INCIDENTAL DAMAGES FOR BREACH OF THIS OR ANY OTHER WARRANTY, EXPRESSED OR IMPLIED, WHATSOEVER. No person or representative is authorized to assume for the Company any liability other than expressed herein in connection with the sale of this product.

The Company does not warrant that this product cannot be compromised or circumvented. THE EXTENT OF THE COMPANY'S LIABILITY UNDER THIS WARRANTY IS LIMITED TO THE REPAIR OR REPLACEMENT PROVIDED ABOVE AND, IN NO EVENT, SHALL THE COMPANY'S LIABILITY EXCEED THE PURCHASE PRICE PAID TO THE PURCHASER FOR THE PRODUCT.

Some states do not allow limitations on how long an implied warranty lasts or the exclusion or limitation of incidental or consequential damage so the above limitations or exclusions may not apply to you. This warranty gives you specific legal rights and you may also have other rights which vary from state to state.

Dakota Digital

3421 W. Hovland Avenue
Sioux Falls, SD 57107
Phone: (605) 332-6513
FAX: (605) 339-4106